

Single Acting Power Unit Installations

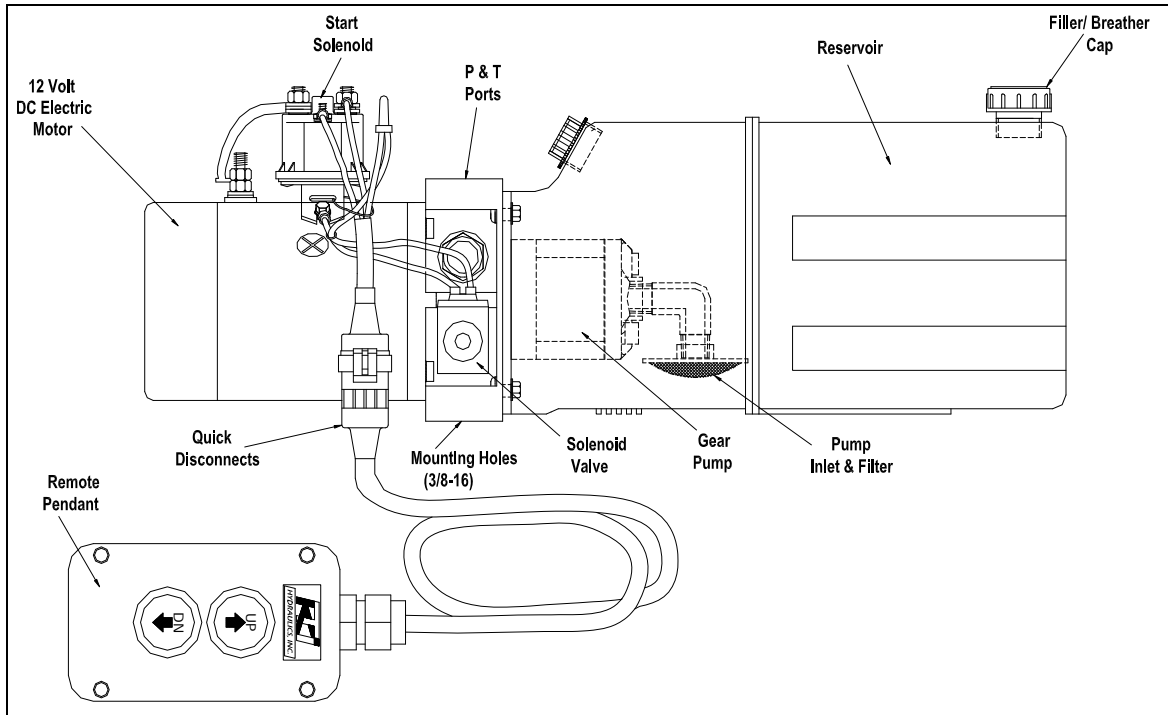

Diagram A-1

1. Install Fittings to P & T or P Port Only (if necessary) Torque to 18 ft-lbs (Port's are #6 SAE female O-ring Boss)
2. Detach Remote Pendant From Power Unit
3. Mount Power Unit using 3/8-16 Mounting Bolts
4. Remove Filler/Breather Cap to Fill Power Unit With Hydraulic Fluid & Replace When Finished (see fluid recommendations)
5. Connect Hydraulic Lines to Power Unit
 - a. Check Torque Specifications for Hose Fitting
 - b. Connect Base of Cylinder to P Port
 - c. Connect Rod End Of Cylinder to T Port (if second hydraulic line is provided)
6. Connect Ground Wire to Vacant Start Solenoid Screw on DC Motor (see diagram A-3) (Minimum 4 gauge Wire)
7. Connect Positive Cable From Battery to Start Solenoid
 - a. Battery Cable Gauge Selection Guide to Insure Proper Wire Gage has Been Selected
 - b. Torque to 10 ft-lbs. (Over Tightening Studs on Start Solenoid Will Break Solenoid Case)
8. Connect Remote Pendant To Power Unit
9. Operate Power Unit While Also Keeping an Eye on Fluid Level In Reservoir (Insure Fluid Level Never Goes Below 2" From the Bottom of Reservoir)
 - a. Extend Cylinder Half Way Then Retract Cylinder
 - b. Check Fluid Level & Fill Reservoir to Fill Line
 - c. Fully Extend Cylinder While Insuring Fluid Level Exceeds 2" from Bottom of Reservoir
 - d. Only Add Additional Fluid to Reservoir when Cylinder is fully Retracted
10. Run the Cylinder Up and Down Until All the Air is out of the Hydraulic System
11. Fill Reservoir to Full line On Reservoir or Dipstick on Filler/Breather Cap

Caution: Cutting Safety Wire or Tampering with Relief Valve Will Void Warranty, And May Cause Injury or Even Death.



Fluid Recommendations

KTI recommends using top-quality hydraulic fluids with ISO VG 22 – 68 (19.8 – 74.8 cSt, 97 – 347 SUS at 40°C) to ensure optimum performance and system life. Fluids should have anti-wear properties, rust and oxidation inhibitors. If using synthetic fluids, consult the factory for alternative seal material requirements. **Do Not Use Biodegradable Hydraulic Fluid**

Fluid Temperature Range	ISO Viscosity Grade (ISO VG)
-5°F to + 140°F -21°C to + 60°C	22
+5°F to + 170°F -15°C to +77°C	32
+15°F to + 190°F -9°C to + 88°C	46
+30°F to +210°F -1°C to + 99°C	68

Do not operate Power Unit above recommended Fluid Temperature Range.

Premium hydraulic oil with proper ISO Viscosity Grade and additives such as Chevron EP, Mobile DTE 10, DTE 20 series, or Shell Tellus would be acceptable.

In Most Applications Use ATF Dextron III

Battery Cable Gauge Selection Guide

When Selecting Battery Remember If you Increase the Distance From the Power Source You Need to Increase the Gauge of the Wire. Never Mount a Power Unit More than 19 Feet from Power Source
If Improper Battery Cable is Selected Power Unit Will Exhibit low Battery Symptoms Which Include High Amp Draw.

- 1 to 2 Feet use 4 Gauge Cable
- 3 to 4 Feet use 2 Gauge Cable
- 5 to 7 Feet use 1 Gauge Cable
- 8 to 9 Feet use 01 Gauge Cable
- 10 to 12 Feet use 02 Gauge Cable
- 13 to 15 Feet use 03 Gauge Cable
- 16 to 19 Feet use 04 Gauge Cable

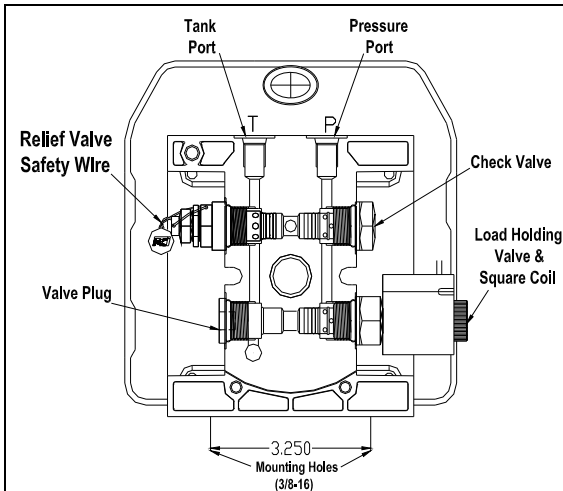

Diagram A-2

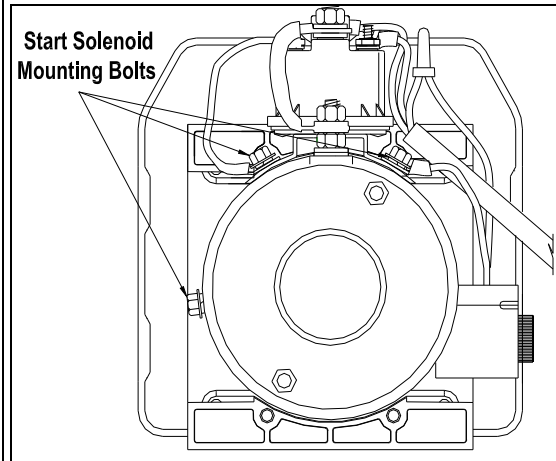

Diagram A-3

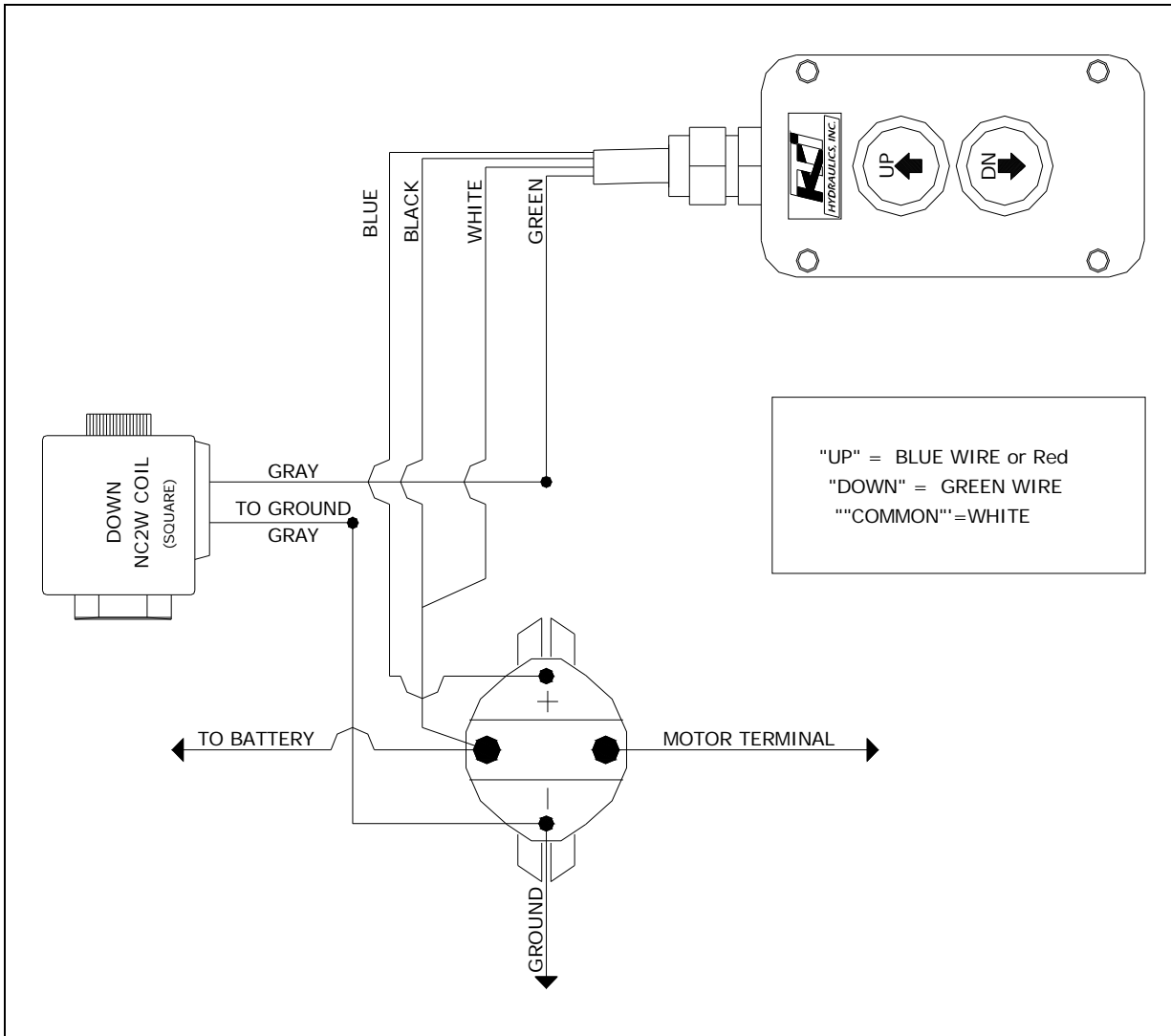

Diagram A-4